

DOL 58 weather sensor

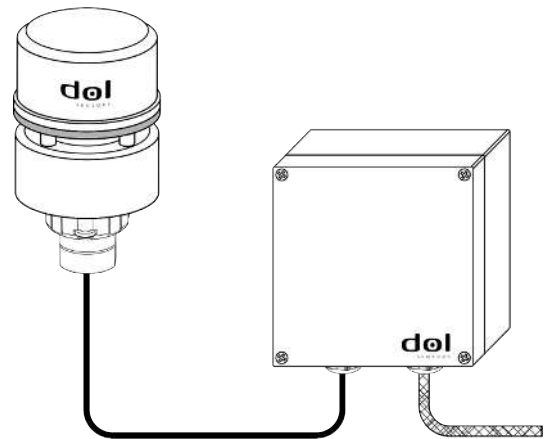

1 Product description

The DOL 58 measures wind direction, wind speed and air pressure/temperature (optional). Wind speed and direction are measured using ultrasound. The weather station thus has no movable parts, which means it is extremely reliable and has an exceptionally long lifetime.

DOL 58 includes:

- Weather sensor
- Connection box
- 5 m/ 16 feet cable to connect the weather sensor with the terminal box
- Mounting bracket for the weather sensor

DOL 58's connection box has three analog outputs:

- Wind direction
- Wind speed
- Air pressure or temperature (supplied upon request)

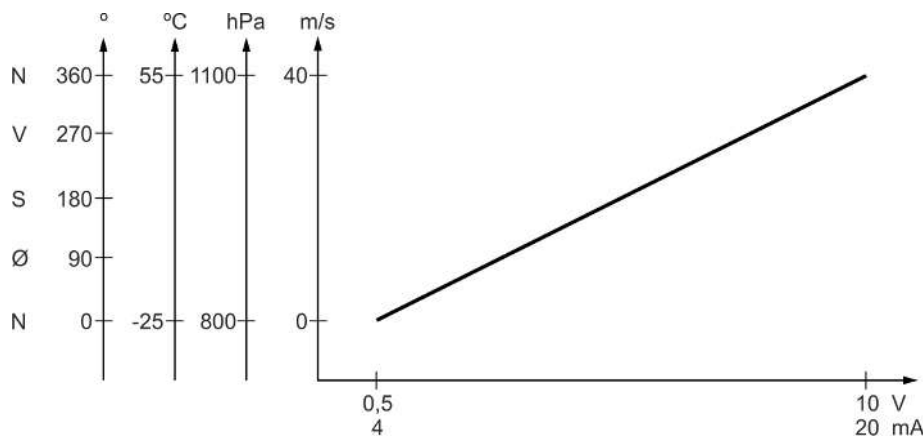

Connection between weather measurement and the analog outputs.

2 Mounting guide

In order to achieve the best possible readings from the weather sensor it is important that the sensor has an “unrestricted view” on all sides. Be careful that rooftops, chimneys, trees, etc. do not block this “unrestricted view” to the weather sensor.

The weather sensor should be mounted on a mast with the accompanying bracket at a minimum of 1.50 m (5 feet) above the ridge of the roof, for example. If using the same mast for e.g. the WLAN antenna, then the weather sensor must be placed at the top of the mast and a minimum of 1 m (3.3 feet) above the WLAN antenna.

It is important:

- that the mast is 100% vertical, as errors will otherwise occur in the readings.
- that the north indicator points northwards.

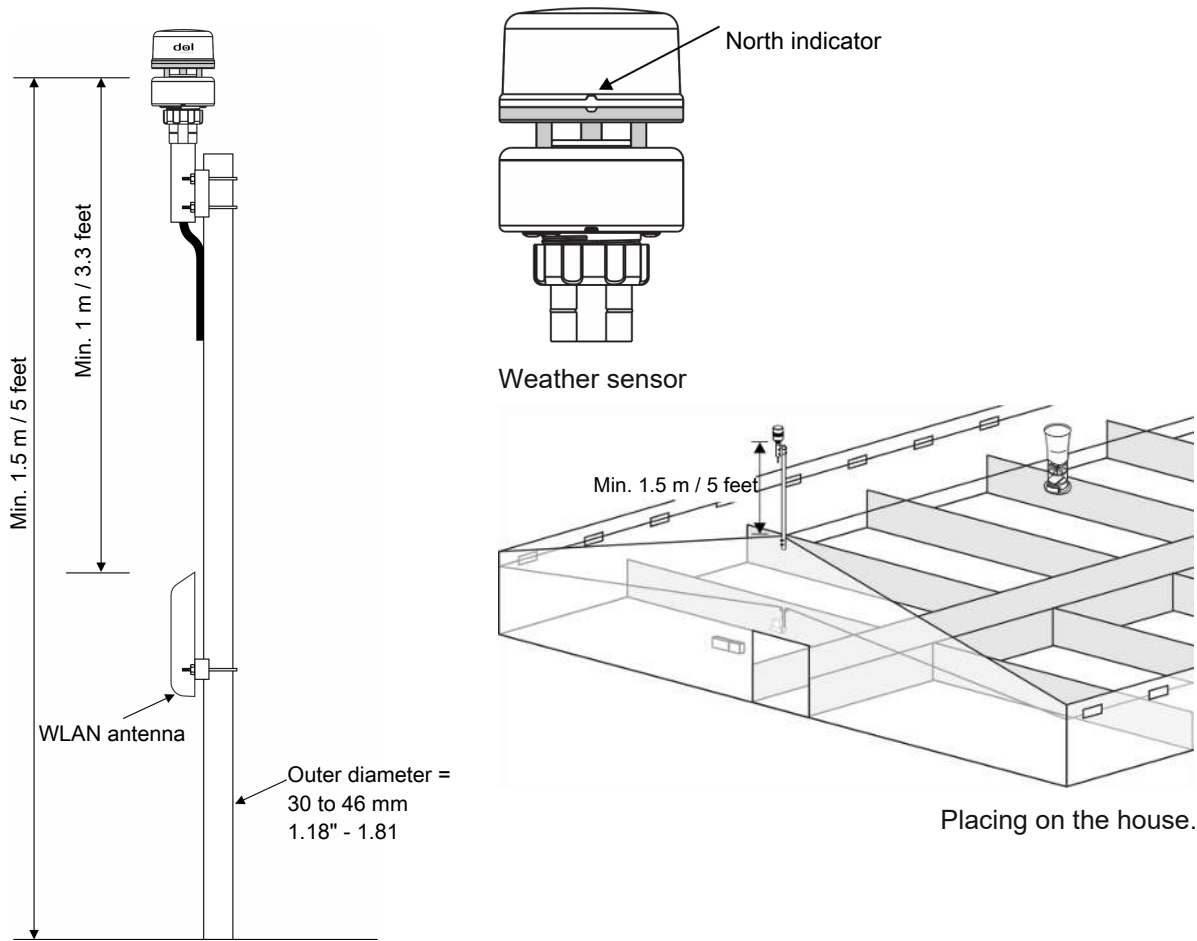

Placing in relation to e.g. the ridge of a roof and any WLAN antenna.

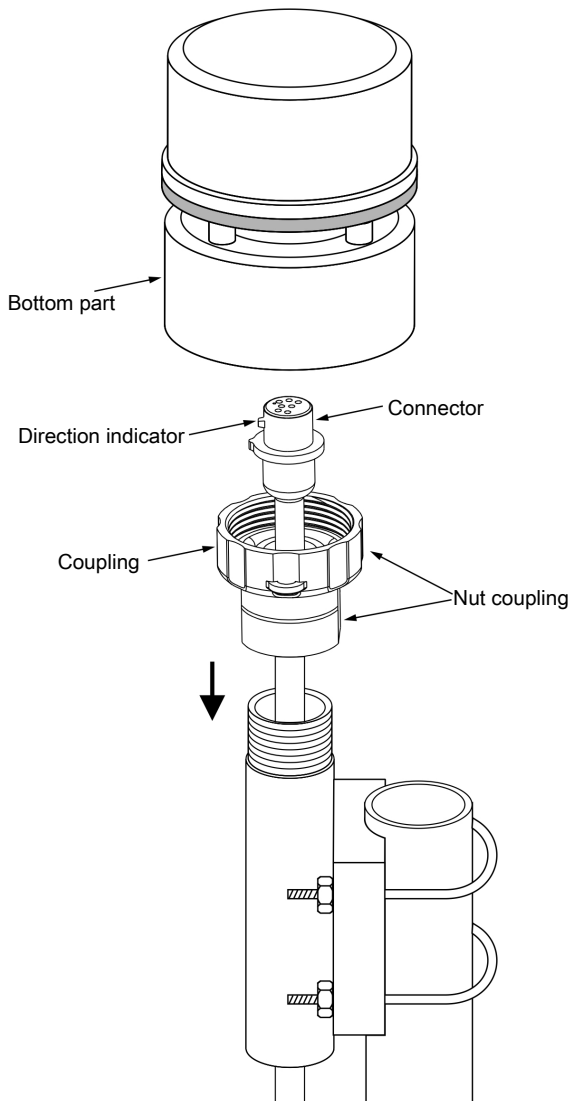

1. Secure the mast bracket to the mast.
2. Pull the cable between the weather sensor and the connection box through the mast bracket. The cable between the weather sensor and the mast bracket is not rodent-protected.
3. Tighten the nut coupling on the mast bracket (*tighten by hand only*).
4. Mount the plug on the weather sensor.
5. Tighten the coupling securely onto the weather sensor. Hold onto the bottom part of the weather sensor only (*tighten by hand only*).
6. The gasket must be adapted to the actual cable with the sealing ring provided.
7. Mount the connection box with the four screws supplied.

Avoid tightening or adjusting the weather sensor by turning the top part of the sensor.

3 Installation guide

3.1 Electrical connection



Installation, servicing and troubleshooting of all electrical equipment must be carried out by qualified personnel in compliance with the applicable national and international standard EN 60204-1 and any other EU standards that are applicable in Europe.

The installation of a power supply isolator is required for each motor and power supply to facilitate voltage-free work on the electrical equipment. The power supply isolator is not included.

3.1.1 Connection of weather sensor

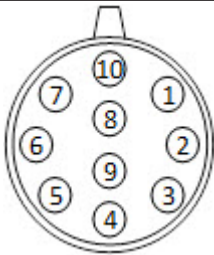
Number	Wire color	Plug connectors
1	Red (RD)	
2	Black (BK)	
3	White (WH)	
4	Not connected	
5	Not connected	
6	Not connected	
7	Yellow (YE)	
8	Orange (OG)	
9	Blue (BU)	
10	Not connected	

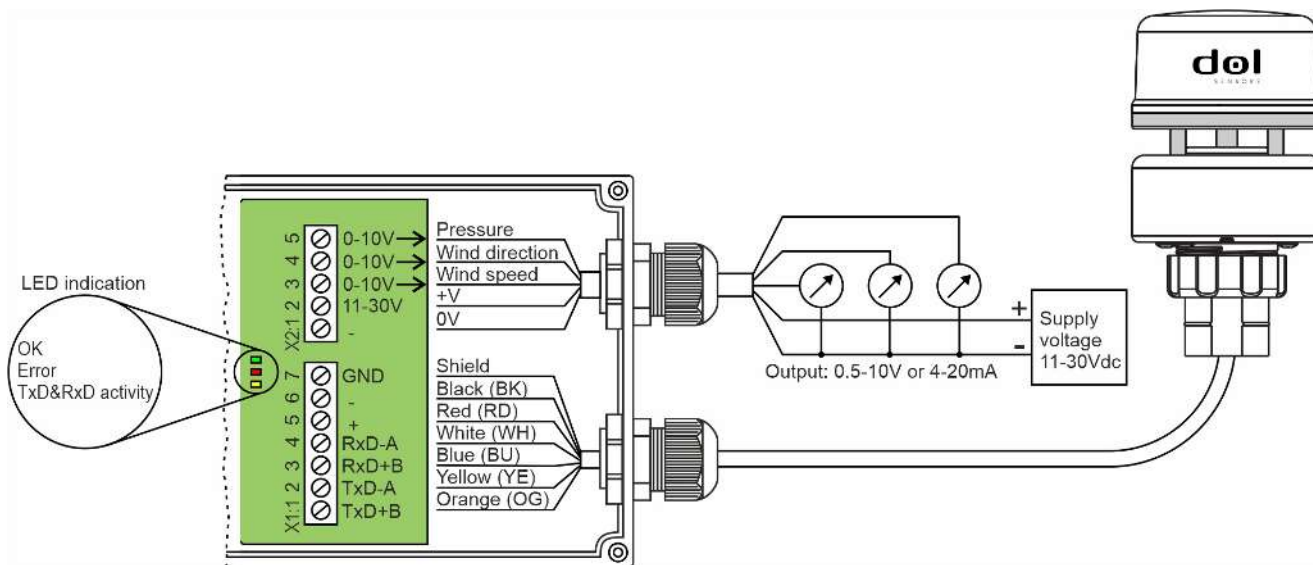

LED indication	LED designation	DOL 58 status
Green ON	OK	Operation OK
RED flash	Error	Overvoltage or undervoltage alarm
Red ON		Overloading of output 1-3
		Connection error at output 1-3: Voltage output: Load <math>< 500\Omega</math> Current output: Load.
Yellow flash	TxD&RxD activity	TxD/RxD activity
Yellow ON		RxD/TxD error in the communication to the weather sensor

4 Maintenance

The sensor has no movable parts and thus does not require regular maintenance.

- ! Possible reduced function can be caused by spider webs, insects or dirt in the wind channel. The wind channel can be cleaned carefully with a damp cloth. During cleaning, it is important not to damage the reflector plate or the protective film in the wind channel, as these are important for optimal function of the weather sensor.

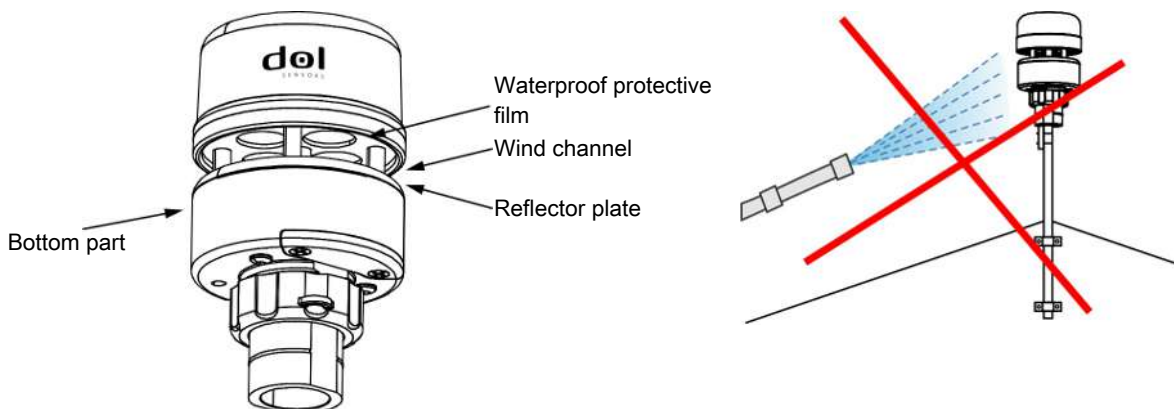

5 Technical data

Input measuring range			Voltage output			Current output	
Wind speed at 0-55 °C	Measurement range	0 - 40	m/s	0.5 - 10	VDC	4 - 20	mA
	Resolution	0.05	m/s	11.88	mVDC	20.00	µA
	Accuracy	0 - 5m/s: 0.50 + 10% of reading	m/s	0 - 5m/s: 11.88 or 10% of reading	mVDC	0 - 5m/s: 200 or 10% of reading	µA
		5 - 40m/s: 1.00 or 5% of reading	m/s	5 - 40m/s: 23.75 or 5% of reading	mVDC	5 - 40m/s: 400 or 5% of read- ing	µA
Wind direction at 0-55 °C	Measurement range	0 – 360		0.5 - 10	VDC	4 - 20	mA
	Resolution	0.1		2.63	mVDC	4.44	µA
	Accuracy	2 – 5m/s: 5.00		2 – 5m/s: 131.66	mVDC	2 – 5m/s: 222.22	µA
		>5 m/s: 2.00		>5 m/s: 52.67	mVDC	>5 m/s: 88.89	µA
Barometric pres- sure	Measurement range	800 – 1100	hPa	0.5 – 10	VDC	4 - 20	mA
	Resolution	0.1	hPa	3.17	mVDC	5.33	µA
	Accuracy	+/- 1.00	hPa	+/- 31.67	mVDC	+/- 53.33	µA
Air temperature	Measurement range	-25 - 55	°C	0.5 - 10	VDC	4 - 20	mA
	Resolution	0.1	°C	11.88	mVDC	20.00	µA
	Accuracy	>2 m/s: +/- 1.1	°C	>2m/s: +/- 130.63	mVDC	>2m/s: +/- 220.00	µA

Input measuring range			Voltage output		Current output	
Load			500Ω - 10MΩ Recommended load ≥ 100 kΩ		See graph	
Output imped- ance			<1Ω		n/a	
Output current			<20mA per output (current limited)		n/a	
Max. cable length			100m @ 0.75 mm ² , AWG18 200m @ 1.50 mm ² , AWG15		n/a	
Common						
Supply	Voltage	VDC	11 - 30			
	Current	mA	@ 12 V DC Typ. 70mA, max. 130 @ 24 V DC Typ. 50mA, max. 110			
Temperature, operation	°C	-25 - 55				
Shipping weight	kg	1.9				
Shipping dimen- sions	mm	380 x 185 x 165				
Protection class	IP	Interface box: 65 Weather sensor X6 (Relative humidity/X4)				
Approval		CE				
Mounting	Mast outer diameter Ø 30 to 46 mm (1.18" to 1.81")					

When the wind speed is less than 2 m/s and the temperature is below 0 °C, the readings will be less accurate.

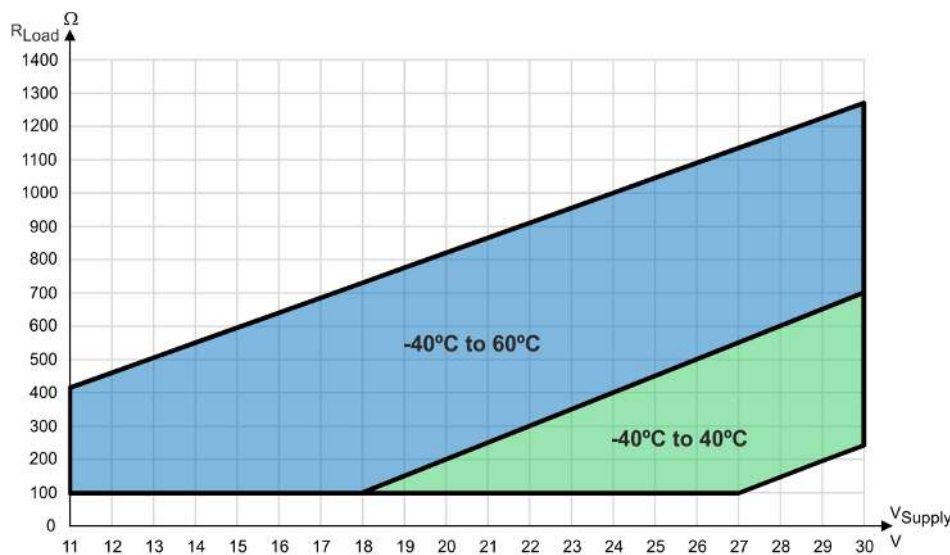

Load resistance and supply voltage.

5.1 Dimensions

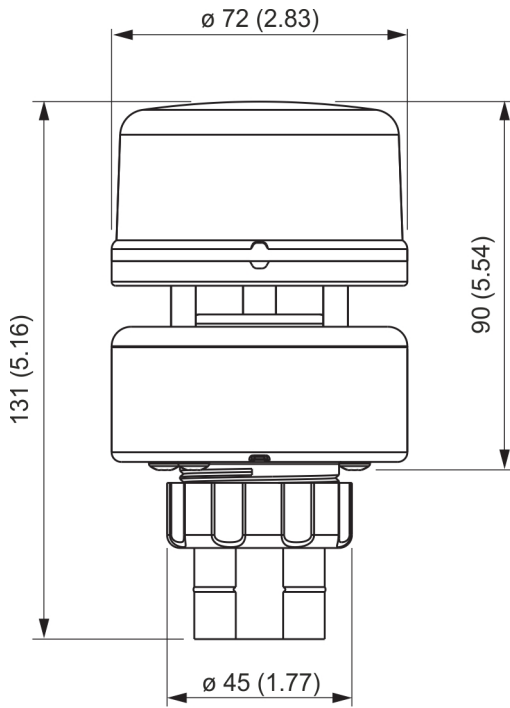

Sensor dimensions mm (inches).

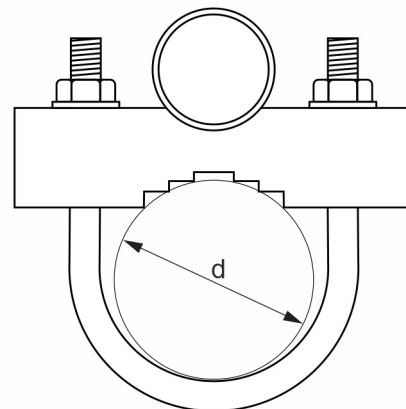
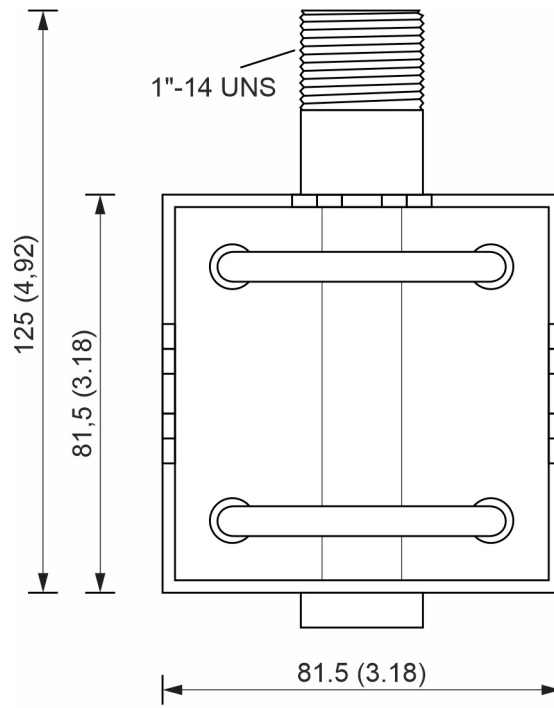

Mounting bracket dimensions mm (inches).

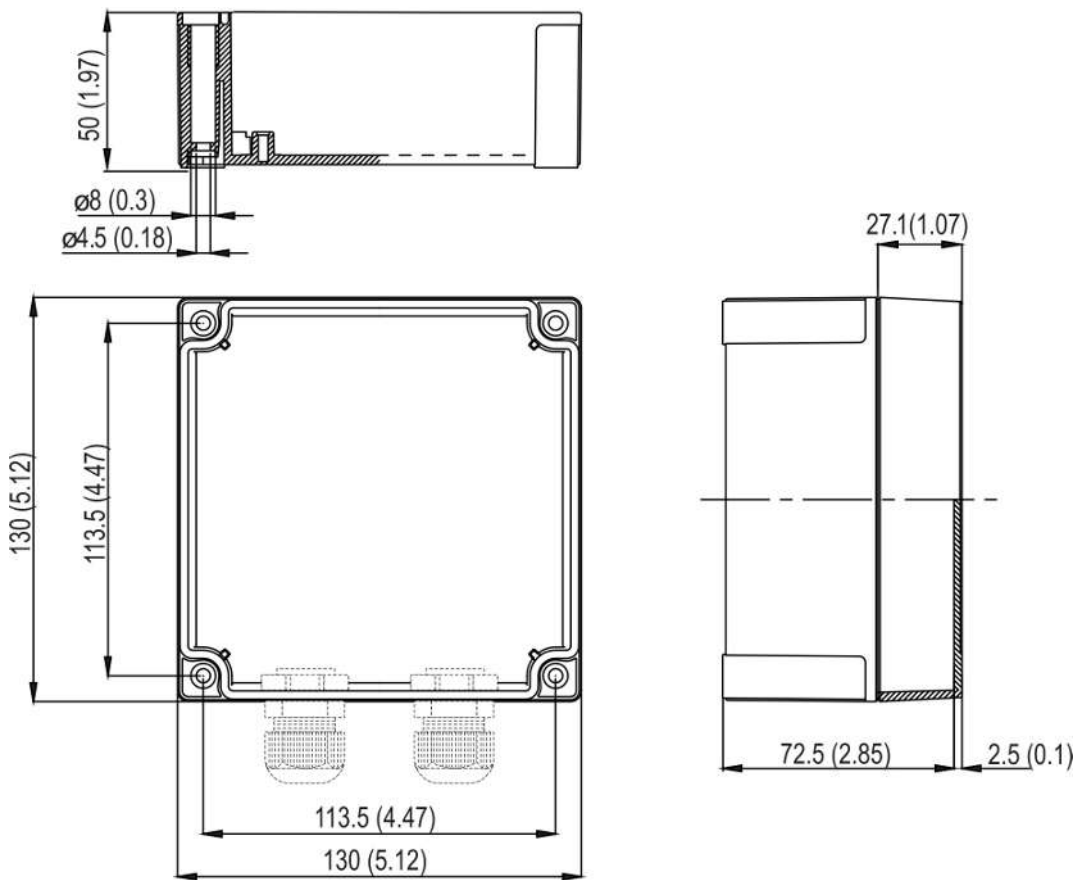

Interface box dimensions.

